

Continuous cleaning of forming wires, press felts and dryer fabrics

Or: How to lower water and power consumption and increase production efficiency and output in Paper Machines at the same time.

Claus Robberts, Founder and Owner of ProJet b.v.

INTRODUCTION:

In a paper machine, there are 3 main stages or sections of the manufacturing process, all having their specific task to obtain the desired paper properties:

- Forming Section: formation of the sheet (strength, thickness, etc)
- Press Section: surface properties (printability, etc)
- Dryer Section: dryness at the end of the production process

Each section has one or more conveyors to support the paper sheet while it's being manufactured; Wires in the Forming Section, Felts in the Press Section and Fabrics in the Dryer Section. The conveyors are generally referred to as "Paper Machine Clothing" or PMC.

The benefits of consistently clean machine clothing

Clean PMC, with consistently high permeability and dewatering capabilities, delivers important productivity and performance advantages. Consistently clean Forming Wires give better dewatering in the Wire Section which leads substantial improvement in dryness level when the sheet leaves the Forming Section, into the Press Section. Forming Wires loose dewatering ability when contamination builds up over time during production. Cleaner Press Felts assure improved sheet surface, better dewatering and therefore higher dryness levels when the sheet enters the Dryer Section, so less drying energy is required there. Clean Dryer Fabrics with high permeability or porosity provide highest drying capacity so less steam consumption is required. At the same time, much less contamination will be deposited on dryer cans, doctor blades, and felt rolls.

More and more contamination (fillers, broke, pitch, stickies, etc.) can be found on PMC caused by an increasing use of secondary fibers, recycling of coated broke, increasing use of sheet fillers, an increased use of recycled mill water supplies, and the increased use of process chemicals.



Advantages of Continuous PMC Cleaning

ProJet is a globally operating company with over 30 years experience in designing, manufacturing and supplying innovative High Pressure Cleaning systems for paper machines. Over 1,500 ProJet cleaning systems are successfully installed and running in paper manufacturing processes worldwide. The ProJet system consumes very little water, compressed air, and very little electrical energy; all much less than conventional cleaning showers. This innovative cleaning system is being applied successfully to very low basis weight paper product as well as heavy weight paper board applications. Applying a ProJet Cleaning Solution guarantees consistently clean PMC from beginning to end of the usable life, while using a minimum of utility resources. Consistently clean PMC delivers the following significant manufacturing advantages:

- Conventional HP showers can be switched off leading to enormous water consumption and power consumption savings.
- No shutdowns will be required for manual or chemical PMC cleaning. This will provide increased manufacturing productivity and profitability.
- Maintaining consistently high PMC permeability and dewatering capabilities increases dryness and quality of the sheet, leading to less reject and higher profitability.
- Better CD sheet moisture profiles will be maintained.
- Sheet curling, caused by uneven moisture profile, will be eliminated.
- PMC life will be substantially improved.

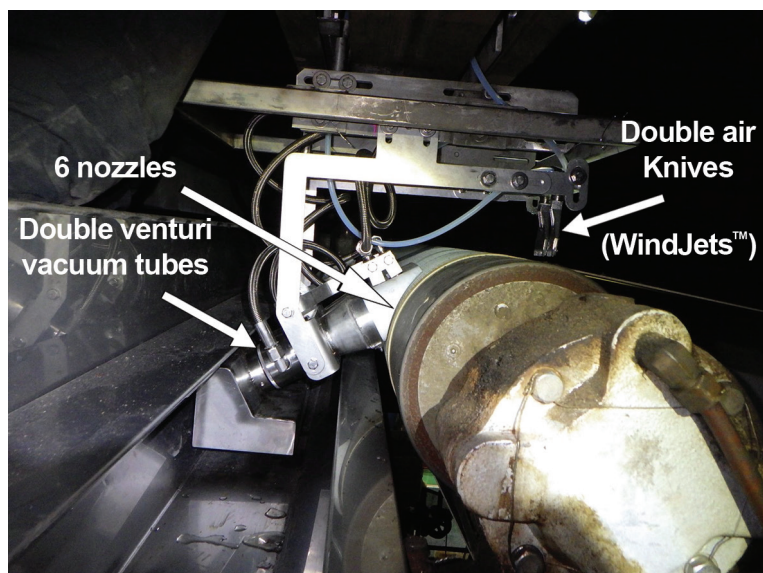

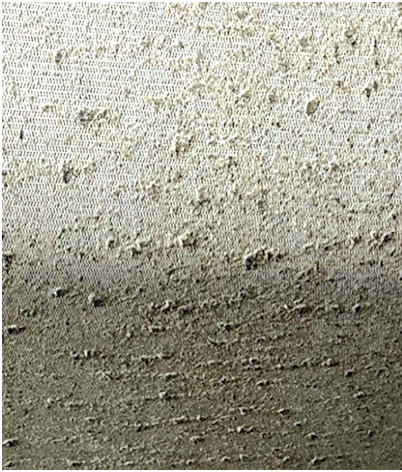

Figure 1a & 1b: Clean a dirty dryer fabric within 12-24 hours and then maintain this cleanliness 24 / 7.



Figure 2: Power Cleaner 2.0 on Bottom Fabric

Power Cleaner

ProJet's Power Cleaner systems all use a highly reliable traversing beam with a single oscillating cleaning head with multiple nozzles and high pressure water, all designed for the specific position in the machine. The cleaning head is equipped with vacuum and air knives leading to the following features and benefits:

- The vacuum and debris discharge system allows the Power Cleaner to operate completely mist free, opposed to conventional showers, leading to a much cleaner machine and work environment.
- Debris and contaminants are discharged, away from the manufacturing process, eliminating the risk for re-contamination.
- The head can be sent to particular trouble zones, providing targeted and more efficient cleaning than conventional showers.
- The head can be parked outside the paper machine, allowing for nozzle changes during the production process

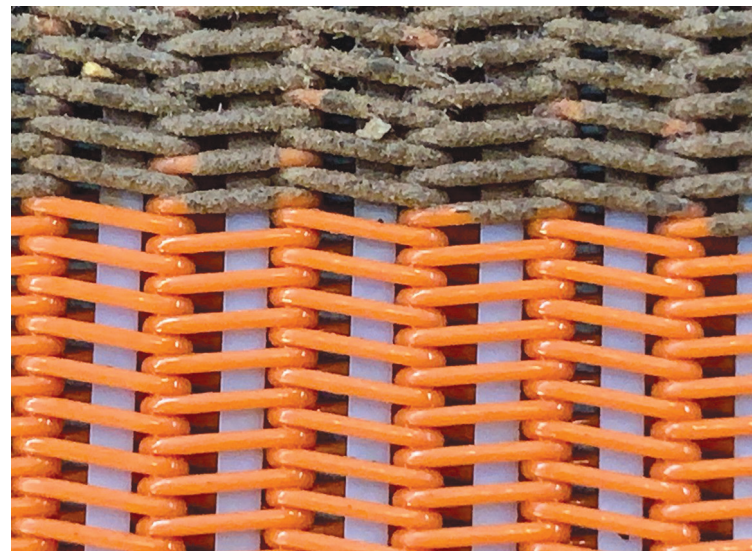

Figure 3: ProJet clean.

ROI calculator

ProJet understands that each client application is unique. For that reason, ProJet developed an automated ROI-calculator that will be applied to each application and produced paper grade.

By contacting

info@projetinc.us or

info@pro-jet.nl ProJet

ProJet will perform a no-charge ROI calculation of any Forming Wire, Press Felt or Dryer Fabric application. After inputting the process parameters provided by customers, they will be provided with a ROI-Analysis of each specific application and investment justification.

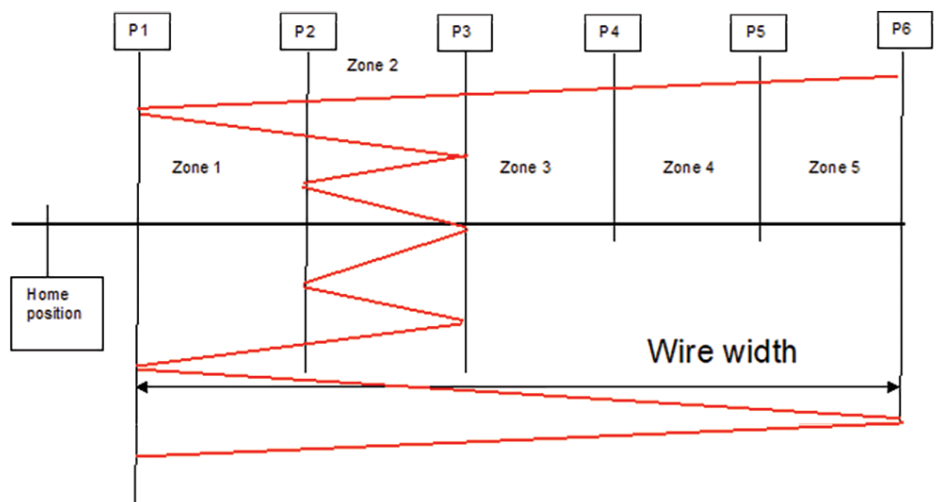

Figure 4: Strip- & Zone cleaning.