

How to prevent problems at film presses or coating units!

Are you responsible for the film press or coating unit at your paper machine? If yes, you are for sure struggling with problems coming from the metering rod beds, the rods or other parts installed in that area. We have the solution - promised. Read on!

Are you familiar with damages like these?

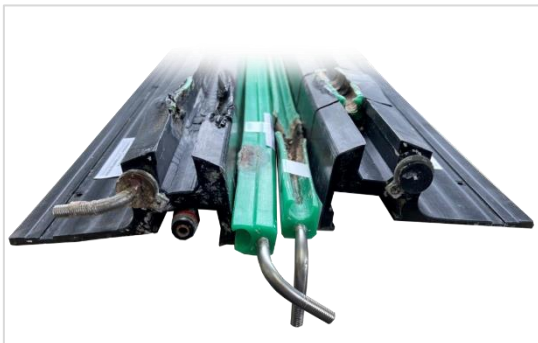

Unfortunately, many paper makers answer this question with "yes". But how would you answer?

Coating units or film presses are part of many paper machines, but they often struggle with undefined short lifetime cycles of the installed metering rod beds and rods. Where do they come from and why do they occur? The answer could

be much more simple than you might think. There is often the risk of a **thermal overheating** at both end areas that shortens the lifetime of rod beds as well as **leads to consequential damages** like plugged lubrication slots, leakage of flushing water or even damages on the applicator rolls.

About 80% of rod beds need to be changed because of thermal overheating in the end areas. But thermal overheating can be prevented very easily.

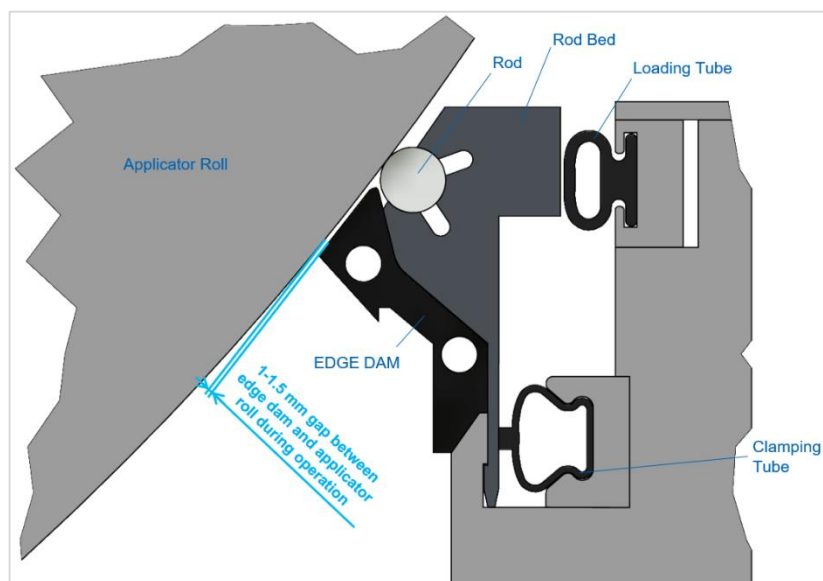

Thanks to many years of experience in process optimization, Röchling exactly knows how to avoid this issue. Using the high-quality metering rod beds and rods from Röchling Industrial Oepping as well as the perfect fitting Edge Dams might be the answer.

A perfect adjustment of the Edge Dams with a gap of 1-1.5 mm to the applicator roll ensures that there is no dry spot and no risk of temperature increase. Röchling Industrial Oepping supplies Edge Dams with highest homogeneity and maximum protection to the roll cover.

Also very important to prevent any dry spot is the proper function of the Edge Shower Nozzles. They should be permanently checked, because their water film is essential for a smooth run. They protect the roll cover, rod bed and rod. Looking at the illustration below there is an example showing the loss of one nozzle. Looking at the whole machine width, it is only a small space, but exactly this small dry space can lead to a significant risk of a dry area resulting in thermal overheating.

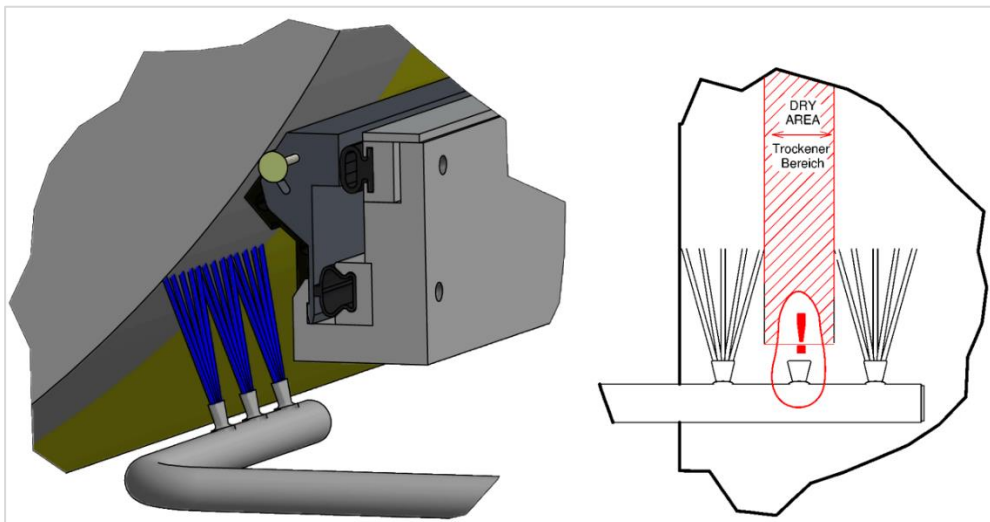

Injuries during installation of rod beds and rods



Working safety is more important than ever. Less space at the coating head as well as heavy rods and beds which are slippery and uncomfortable to carry often lead to critical situations. Unfortunately **risks of bruises and cuts on fingers** are common struggles. When replacing rod beds and rods, operators come dangerously close to the razor-sharp sealing blade, for

example. A seemingly harmless replacement can quickly become a dangerous affair! That's why working safety must not be underestimated. So, how can you prevent such dangerous situations?

To avoid any injuries during the assembly, Röchling Industrial Oepping developed unique



carrying handles for rod beds. This carrying handles can only be used in combination with ROBACOAT rod beds. Operators benefit from a safe handling without slipping away during carrying as well as less physical stress of the rod bed by perfect weight distribution.

Having an eye for problems on-site and finding solutions are challenges which Röchling Industrial Oepping ist dealing with for decades. The latest development like the carrying handle is only one example showing the innovative spirit of the company. Röchling is the perfect partner for innovative solutions and strategic developments.



Mr. Martin Schaubmaier

Product Manager for Robacoat

T +43 (0) 7289 4611-242

M +43 (0) 664 845 17 51

MSchaubmaier@roechling.com